

## #1 TABLE GRAPE SPRAYER ON THE MARKET



### SCAN QR CODE TO LEARN MORE

Scan to contact your nearest Grower Services dealership for pricing, availability, and expert advice on the Interlink Power Tube range.

Request a quote and speak with the team about the best sprayer setup for your operation.

# INTERLINK

ULTIMATE CROP PROTECTION

# POWER TUBE



## TOTAL AIR DISPLACEMENT

Complete leaf coverage with advanced air displacement, **41,900m<sup>3</sup>/hr** airflow, and **9kW** fan power.

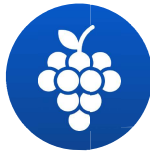

## UNIFORM COVERAGE

Deviated air system with adjustable airflow up to 15° forward/back and 25° up/down for multi-angle canopy coverage.



TRUSTED BY OVER  
**1000+**  
**FARMERS**  
IN AUSTRALIA

## TECHNOLOGY IN DETAIL

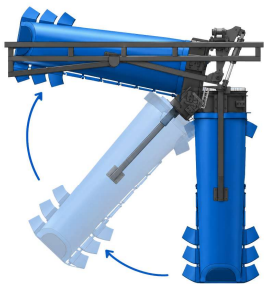

### HYDRAULIC FLIP-UP ARMS

Heavy-duty hydraulic rams actuate a rotating cylinder joint, allowing the Power Tube to **pivot up to 115°** for improved manoeuvrability between rows and compact transport storage.

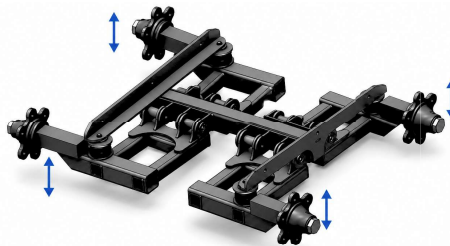

### SUSPENSION AXLE SYSTEM

Heavy-duty 2 or 4-wheel independent suspension axle fitted with **fully sealed 70mm stub axles** for superior stability and smooth towing performance.

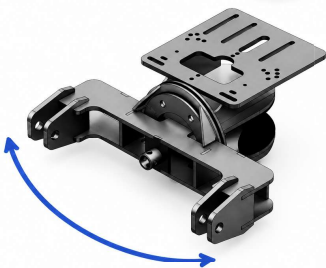

### 2-POINT TOW HITCH

Heavy-duty twin tow hitch featuring durable **nylon pivot points**, **30° lockout**, and up to **110° turning** for exceptional stability and manoeuvrability.

## POWER TUBE OVERVIEW

APPLICATION TYPE:	Vineyard / Orchard
TANK SIZES:	2000-5000L
HITCH TYPE:	2-Point Tow Hitch
FRAME CONSTRUCTION:	Triple Coated Luxathane
AXLE TYPE:	Suspension Axle
WHEELS SIZE:	400-60-15.5
PUMP TYPE/SIZE:	Bertolini IDB 2000 200L Pump
WATER SECTIONS:	6 ARAG Water Sections
JET TYPE:	ALBUZ 60° Hollow Cone Jets
SPRAY COVERAGE HEIGHT:	2.5m from Ground
ROW WIDTH ADJUST:	10 - 12ft (3 - 3.6m)
HEIGHT ADJUST:	12 - 18" (304.8 - 457.2mm)
COMPUTER/CONTROLLER:	ARAG Bravo 180s
<b>*OPTIONAL ELECTROSTATIC TECHNOLOGY*</b>	
<b>*OPTIONAL TERRACE ADJUST*</b>	
<b>*MINIMUM PTO REQUIREMENT DEPENDS ON BUILD*</b>	

## ROW ADJUST

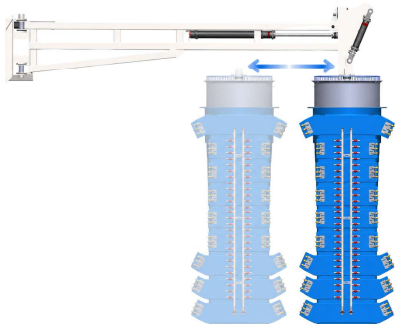

Hydraulic row width adjustment allows the boom arms to extend outward for wider row spacing, with a standard width of **10ft** and hydraulic extension up to **12ft**.

## HEIGHT ADJUST

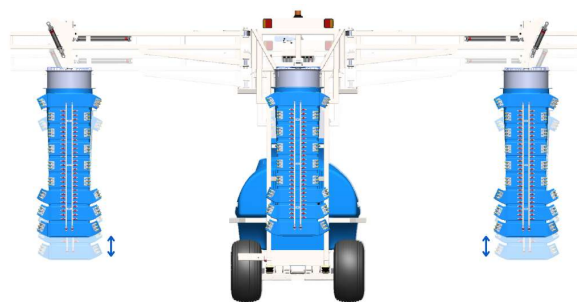

Hydraulic height adjustment raises the rear boom assembly for improved canopy alignment, with a standard **12" adjustment** and optional **18" version available**.

## TERRACE ADJUST (OPTIONAL)



Hydraulic terrace adjustment independently raises and lowers each tube for optimal coverage across uneven terrain and varying row heights.

**FOR CONTACT DETAILS, PLEASE SCAN THE QR CODE ON THE REVERSE SIDE**